

DF-W

系列联锁阀 Series locked solenoid Valves

DF3-W 系列正联锁电磁阀 Series positive locked solenoid valves

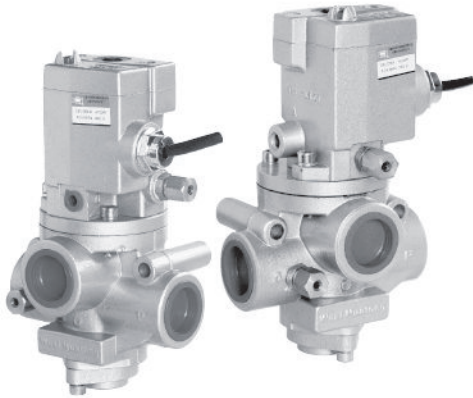

图形符号 Graphical symbols

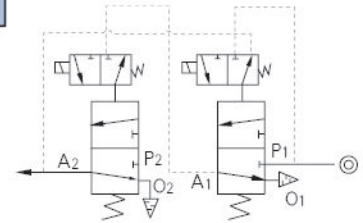

产品特点 Features

DF3-W正联锁阀是控制压力制动器、离合器正常工作的一种专用气动元件。它保证离合器与制动器必须保持一定的结合和脱开顺序。即在压力机启动时，制动器必须首先脱开0.03秒。然后离合器才能结合；在压力机停车时，离合器必须首先脱开0.01秒，然后制动器动作。该阀反应灵敏、动作可靠。

DF3-W positively locked solenoid valve is exclusive pneumatic elements controlling the actions of the brake and clutch of a press. It ensure that clutch and brake maintain a certain procedure of gear in and release, i.e. when press starts the brake shall first release for 0.03 sec before clutch gear-in; and when the press stops, the clutch shall first release for 0.01 sec before brake active.

型号注释 Note for type

DF3 - 20/25 W

- 正联锁电磁阀 Positive locked solenoid valves
- 公称通径 Dia
- 公司代号 Company code

外形尺寸 Outlook & Dimension

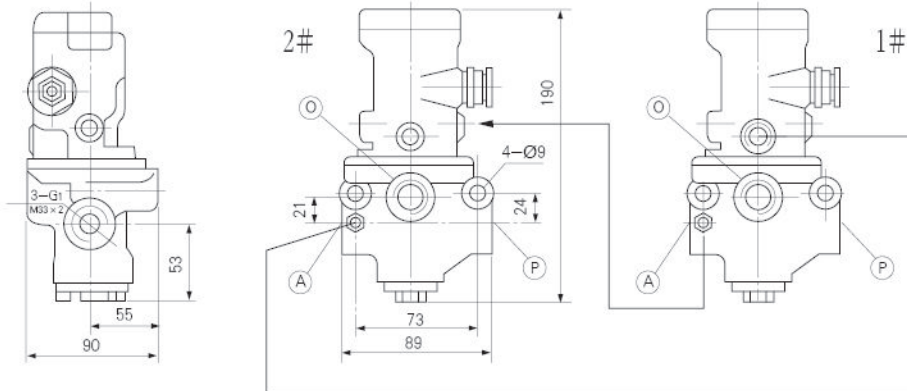

技术参数 Specification

流量 Flow rate(m ³ /h)	30
有效截面积S值 Effective sectional area S valve(mm ²)	190
联锁阀额定工作压力 Working pressure(MPa)	0.2~0.6
电磁阀工作电压 Voltage(V)	AC:220,110,36, DC:110,24 电磁铁工作电压为额定电压的85~105%时可靠工作。 Electrilmagnet operates when its working voltage is 85~105% of nominal voltage
联锁阀延时性能(秒) Time retardation (sec)	≥0.02
环境温度 Ambient temperature(°C)	-5~50
工作介质 Working medium	经净化并含有油雾的气体 Gas cleansed and containing oilmist
联锁阀工作寿命(万次)Working life (10K times)	150