

KJDS 系列电焊机专用电磁阀

Series solenoid valves for welding

K23JD-S 系列二位三通电磁阀

Series 3/2-way solenoid valves

图形符号 Graphical symbols

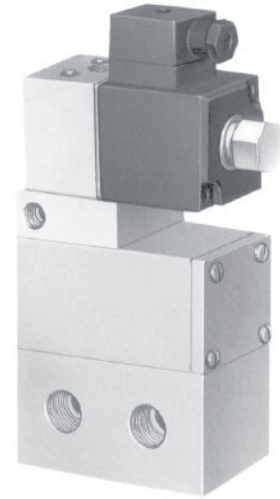
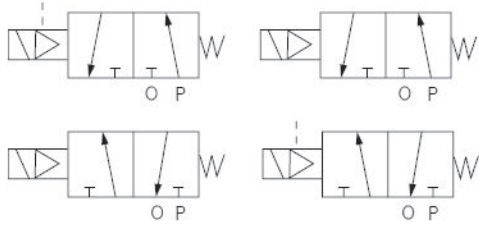

型号注释 Note for type

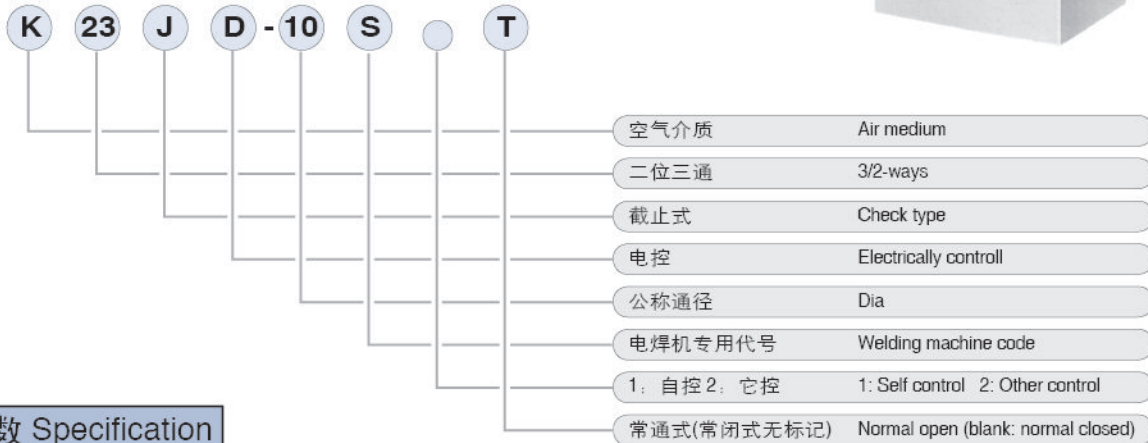

技术参数 Specification

型号 Type	K23JD-10S ₁	K23JD-15S ₁
性能 Item	K23JD-10S ₂	K23JD-15S ₂
公称口径 Dia(mm)	10	15
接管螺纹 Size of port	G3/8	G1/2
工作压力范围 Working pressure range(Mpa)	0.2~0.8	
介质温度 Medium tempt(°C)	5~50	
环境温度 Ambient tempt(°C)	5~50	
换向时间 Diverting time(sec)	≤0.06	
最高切换频率 Max switch over frequency(Hz)	≥8	
有效截面积S值 Effective sectional area S valve(mm ²)	40	60
泄漏量 Leakage rate(mL/min)	≤25	

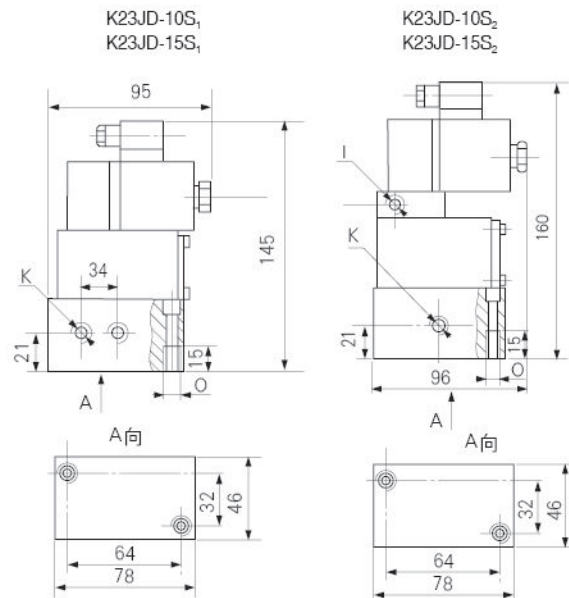

外形尺寸 Outlook & Dimension

螺纹 Threads	K(接管螺纹)	O(连接螺纹)	I(外接螺纹)
型号 Type	(Pipe threads)	(Connect threads)	(Out threads)
K23JD-10S ₁ (T)	G3/8	M8	G1/8
K23JD-10S ₂ (T)	G3/8	M8	G1/8
K23JD-15S ₁ (T)	G1/2	M8	G1/8
K23JD-15S ₂ (T)	G1/2	M8	G1/8